

ESP-Mx WiFi Module

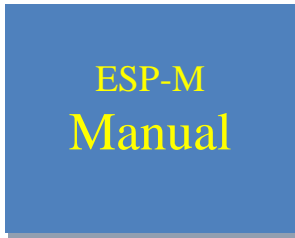

Ver V1.1

Mar., 21, 2017

Num.: DM0014CN

Features

■ SOC features

- Built-in Tensilica L106 ultra-low power consumption 32-bit cpu, the main frequency can be 80MHz and 160MHz, also support RTOS;
- Built-in TCP/IP protocol stack;
- Built-in 1 channel 10-bit high precision ADC;
- Interfaces include HSPI, UART, I2C, I2S, IR Remote Control, PWM, GPIO;
- 20uA deep-sleep current, less than 5uA cut-off current;
- 2ms wake-up time;
- 1.0mW consume power (DTIM3 and standby state);
- Built-in 1M SPI flash byte;

■ Wi-Fi features

- Support 802.11 b/g/n/e/i
- Support three modes: Station, SoftAP, and SoftAP+STA;
- Support Wi-Fi Direct(P2P);
- Support hardware acceleration for CCMP (CBC-MAC, computation mode), TKIP (MIC, RC4), WAPI(SMS4), WEP(RC4), CRC;
- P2P detection, P2P GO mode/GC mode and P2P power management;
- WPA/PA2 PSK and WPS;
- Support 802.11 i security: pre-certification and TSN;
- Support 802.11n (2.4 GHz);
- 802.1h/RFC1042 frame encapsulation;
- Support seamless roam;
- Support AT remote upgrade and cloud OTA upgrade;
- Support SmartConfig function for Android and iOS device.

Module Interface

- 2*UART;
 - 1*En;
 - 1*ADC;
 - 1*wakeup pin;
 - 1*HSPI;
 - 1*I2C;
 - 1*I2S;
 - MAX 10* GPIOs;
- **Working temperature:** -40°C-105°C
 - **Module size:**
12.3*mm*15mm; (M1 version)
12.3*mm*20mm; (M2 version)

Application

- Serial transparent transmission;
- WiFi prober;
- Smart power plug/Smart LED light;
- Mesh networks;
- Sensor networks;
- Wireless location recognition;
- Wireless location system beacon;
- Industrial wireless control.

Module Type

Name	Antenna Type
ESP-M1	IPEX external antenna
ESP-M2	PCB antenna on board

Module Structure

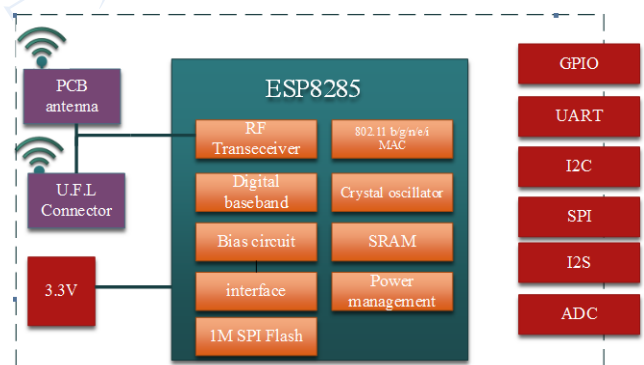

Update Record

Date	Version	Update
Mar, 14, 2017	V1.0	Initial version
May, 11, 2019	V1.1	Upgrade size information

Doctors of Intelligence & Technology
No Duplication

Doctors of Intelligence & Technology
No Duplication

Doctors of Intelligence & Technology
No Duplication

Context

1. Introduction	1
2. Interface Definition	3
3. Shape and Size	5
4. Electronical Characteristics	7
5. Power Consumption	7
6. Wi-Fi RF Characteristics	8
7. The Recommended Sold Temperature Curve	9
8. Minimum User System	10
9. The Recommended PCB Design (An Example)	11
10. Peripheral Line Suggestion	13

1. Introduction

The WiFi module ESP-Mx is manufactured by using a high-performance chip named ESP8285. This small chip is encapsulated an enhanced Tensilica's L106 diamond series 32-bit kernel CPU with a SRAM. Thus, ESP8285 has the complete function Wi-Fi function; it not only can be applied independently, but can be used as a slaver working with other host CPU. When ESP8285 is applied as a slaver, it can start from the onboard Flash. The built-in high-speed buffer is not only benefit to improve the system performance, but optimize the store system. In addition, ESP8285 can be used as Wi-Fi adapter by SPI/SDIO or I2C/UART interface, when it is applied to other MCU design.

The ESP-Mx module supports the standard IEEE802.11 b/g/n/e/i protocol and the complete TCP/IP protocol stack. User can use it to add the WiFi function for the installed devices, and also can be viewed as a independent network controller. Anyway, ESP-Mx module provides many probabilities with the best price.

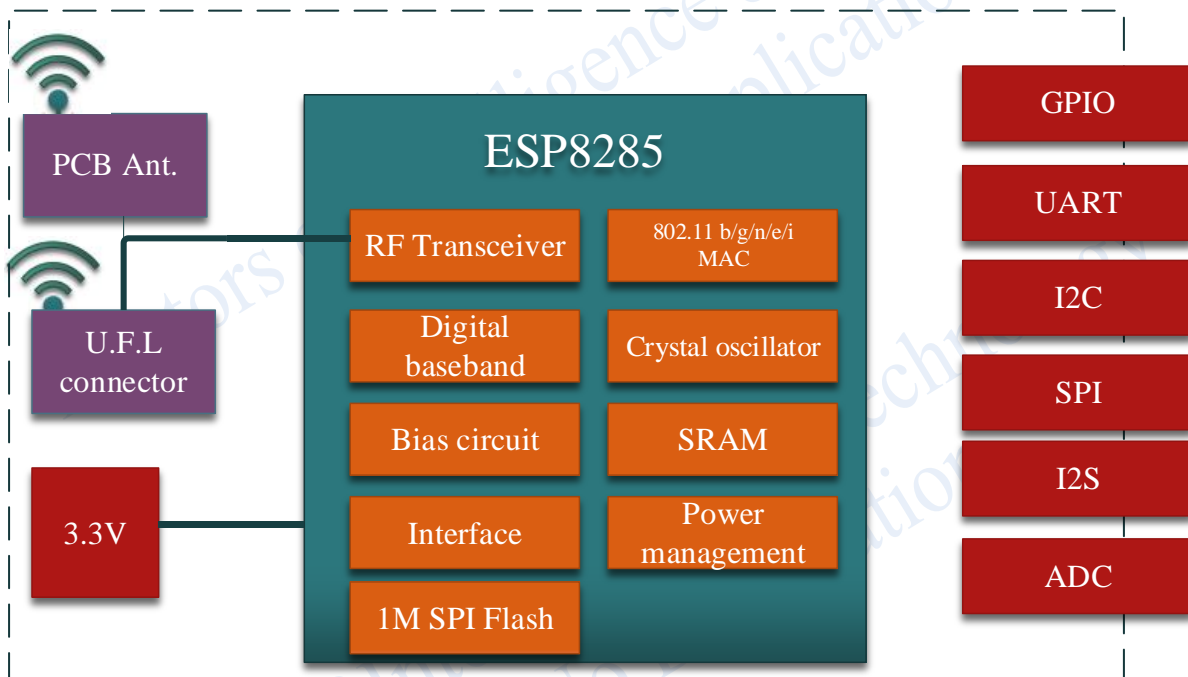

Fig. 1.1 ESP-Mx Module Structure

Technical Parameters for ESP-Mx are listed as follows.

Table 1.1 Parameters for ESP-M

Types	Items	Parameters
Wi-Fi	Frequency	2.4G~2.5G(2400M~2483.5M)
	Transmit power	802.11b: +20 dBm
		802.11g: +17 dBm
		802.11n: +14 dBm
	Receiver sensitivity	802.11b: -91 dbm (11Mbps)
		802.11g: -75 dbm (54Mbps)
		802.11n: -72 dbm (MCS7)
Antenna	PCB antenna / U.F.L antenna	
Hardware	CPU	Tensilica L106 32 bit MCU
	Interface	UART/SDIO/SPI/I2C/I2S/IR control
		GPIO/ADC/PWM/SPI/I2C/I2S
	Working voltage	2.5V ~ 3.6V
	Working current	Average current: 80 mA
	Working temperature	-40 °C ~105 °C
	Environment temperature	-40 °C ~ 105 °C
	Size of ESP-M1	12.3*15*3mm
Size of ESP-M2	12.3*20*3mm	
Software	Wi-Fi working mode	Station/SoftAP/SoftAP+Station
	Security mode	WPA/WPA2
	Encryption type	WEP/TKIP/AES
	Update firmware	UART Download/OTA
	Software develop	Non-RTOS/RTOS/Arduino IDE etc.
	Network protocol	IPv4, TCP/UDP/HTTP/FTP/MQTT
	User configuration	AT+ command/cloud sever/ Android/iOS APP

2. Interface Definition

Interface definition of ESP-Mx can be shown below.

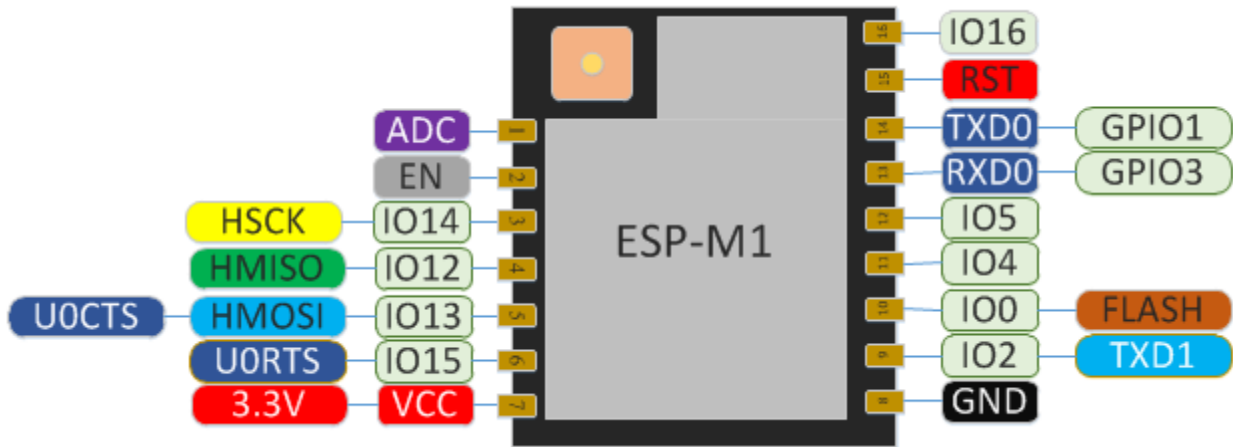

Fig. 2.1 ESP-M1 Pin Definition

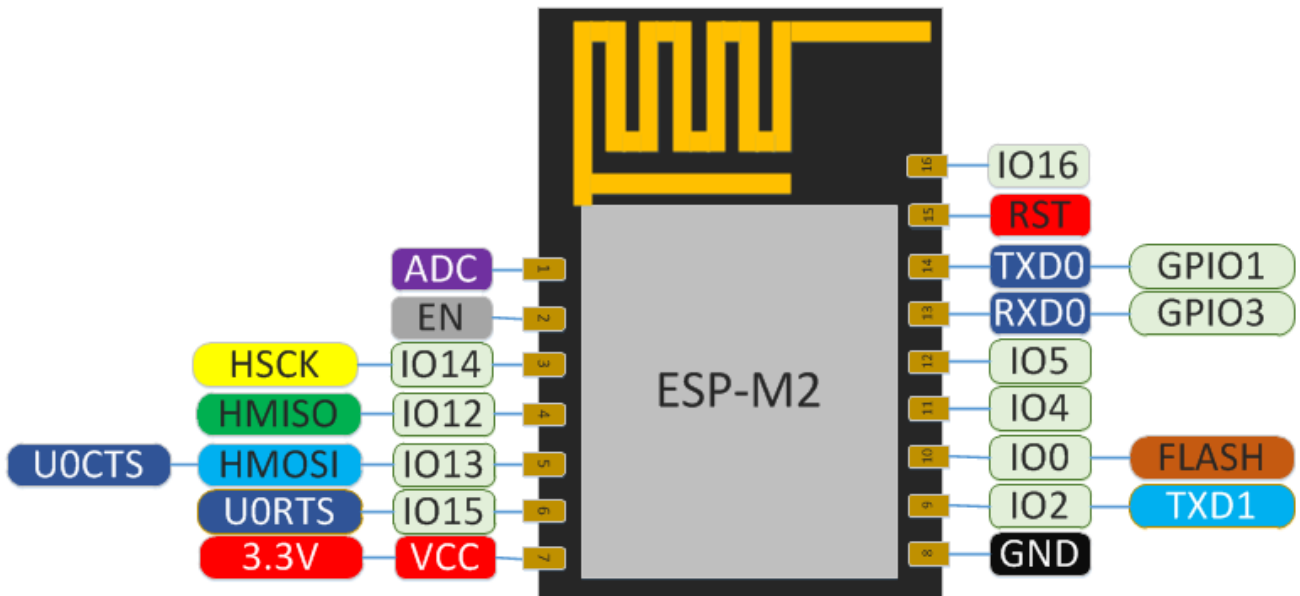

Fig. 2.2 ESP-M2 Pin Definition

Working mode and definition of pins:

Table 2.1 Pin Modes

Mode	IO0	IO2
UART Download Mode	Low level	High level
Flash Boot Mode	High level	High level

Table 2.2 Function Definition of Module Pins

Num	Pin Name	Type	Function Illustration
1	ADC	I	A/D pin. Voltage Range: 0-1V
2	EN	I	Effective: High level
3	IO14	I/O	GPIO14;HSPI_CLK
4	IO12	I/O	GPIO12;HSPI_MISO
5	IO13	I/O	GPIO13;HSPI_MOSI; UART0_CTS
6	IO15	I/O	GPIO15; MTDO;HSPICS;UART0_RTS;
7	VCC	P	Power input: 3.3V
8	GND	P	GND
9	IO2	I/O	GPIO2; UART1_TXD;
10	IO0	I/O	GPIO0; SPI_CS2;
11	IO4	I/O	GPIO4
12	IO5	I/O	GPIO5
13	RXD	I/O	GPIO3; UART0 RX
14	TXD	I/O	GPIO1; UART0 TX
15	RST	I	Effective: Low level
16	IO16	I/O	GPIO16; Used to wake up

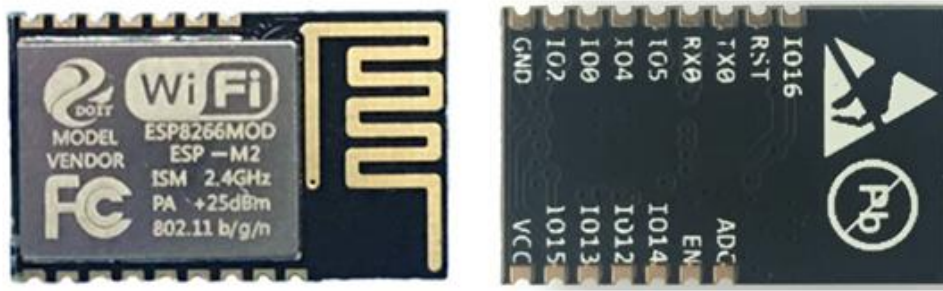
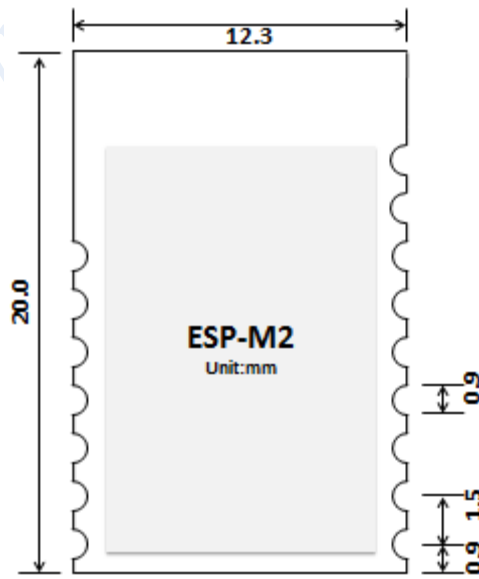
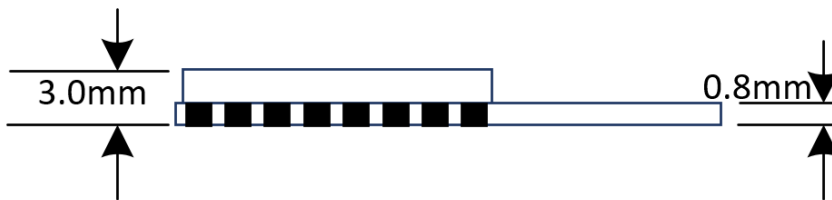

Fig. 3.3 Shape for ESP-M2



(a) Vertical View



(b) Side View

Fig. 3.4 Size for ESP-M1

Table 3.1 Size for ESP-M1

Length	Width	Height	PAD Size(bottom)	Distance between Pins
12.3mm	15mm	3 mm	0.9*1.7mm	1.5mm

Table 3.2 Size for ESP-M2

Length	Width	Height	PAD Size(bottom)	Distance between Pins
12.3mm	20mm	3 mm	0.9*1.7mm	1.5mm

4. Electrical Characteristics

Table 4.1 Electronics

Parameters	Condition	Min	Classical	Max	Unite
Store Temperature	-	-40	Normal	125	°C
Sold Temperature	IPC/JEDEC J-STD-020	-	-	260	°C
Working Voltage	-	2.5	3.3	3.6	V
I/O	V _{IL} /V _{IH}	-	-0.3/0.75V _{IO}	-	0.25V _{IO} /3.6
	V _{OL} /V _{OH}	-	N/0.8V _{IO}	-	0.1V _{IO} /N
	I _{MAX}	-	-	12	mA
Electrostatic release quantity (Human model)	TAMB=25°C	-	-	2	KV
Electrostatic release quantity (Human model)	TAMB=25°C	-	-	0.5	KV

5. Power Consumption

Table 5.1 Power Consumption

Parameters	Min	Classical	Max	Unite
Tx802.11b, CCK 11Mbps, POUT=+17dBm	-	170	-	mA
Tx802.11g, OFDM 54 Mbps, POUT =+15dBm	-	140	-	mA
Tx802.11n, MCS7, POUT =+13dBm	-	120	-	mA
Rx 802.11b, 1024 Bytes, -80dBm	-	50	-	mA
Rx 802.11g, 1024 Bytes, -70dBm	-	56	-	mA
Rx 802.11n, 1024 Bytes, -65dBm	-	56	-	mA
Modem-sleep ^①	-	15	-	mA
Light-sleep ^②	-	0.9	-	mA
Deep-sleep ^③	-	20	-	μA
close	-	0.5	-	μA

Note

①: Modem-Sleep mode can be used for the case that CPU is always working, e.g., PWM or I2S etc. If WiFi is connected and no data is to transmitted, in this case, WiFi modem can be closed to save power energy. For example, if at DTIM3 status, keep asleep at 300ms, Then, the module can wake up to receive the Beacon package within 3ms and the current being 15mA.

②: Light-Sleep mode can be used for the case that CUP can stop the application temporarily, e.g., Wi-Fi Switch. If Wi-Fi is connected and there is no data packet to be transmitted, by the 802.11 standard (e.g., U-APSD), the module can close the Wi-Fi Modem and stop the CPU to save power. For example, at DTIM3, keep up sleeping at 300ms, it would receive the Beacon package from AP after each 3ms, then the whole average current is about 0.9mA.

③ Deep-Sleep mode is applied to the case that Wi-Fi is not necessary to connect all the time, just send a data packet after a long time (e.g., transmit one temperature data each 100s). It just needs 0.3s-1s to connect AP after each 300s, and the whole average current is much smaller than 1mA.

6. Wi-Fi RF Characteristics

The data in the following Table is gotten when the voltage is 3.3V and 1.1V in the indoor temperature environment.

Table 6.1 Wi-Fi RF Characteristics

Parameters	Min	Classical	Max	Unit
Input frequency	2412	-	2484	MHz
Input impedance	-	50	-	Ω
Input reflection	-	-	-10	dB
At 72.2Mbps, output power consumption for PA	15.5	16.5	17.5	dBm
At 11b mode, output power consumption for PA	19.5	20.5	21.5	dBm
Sensitivity	-	-	-	-
DSSS, 1Mbps	-	-98	-	dBm
CCK11, Mbps	-	-91	-	dBm
6Mbps(1/2 BPSK)	-	-93	-	dBm
54Mbps(3/4 64-QAM)	-	-75	-	dBm
HT20, MCS7(65 Mbps, 72.2 Mbps)	-	-72	-	dBm
Adjacent Inhibition				
OFDM, 6Mbps	-	37	-	dB
OFDM, 54Mbps	-	21	-	dB
HT20, MCS0	-	37	-	dB
HT20, MCS7	-	20	-	dB

7. The Recommended Sold Temperature Curve

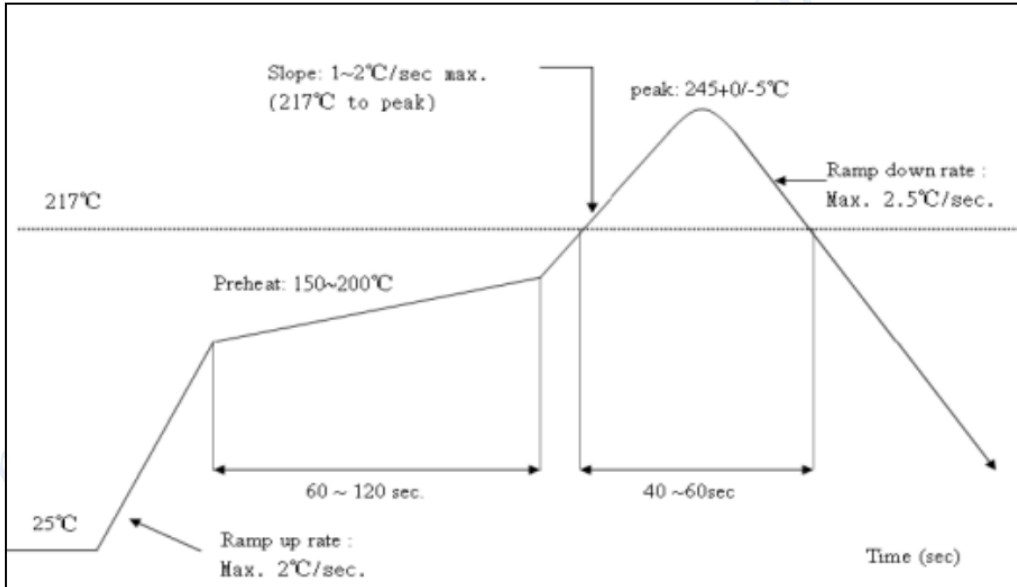

Fig. 7.1 Temperature Curve when Sold

8. Minimum User System

This module can work just at 3.3V working voltage.

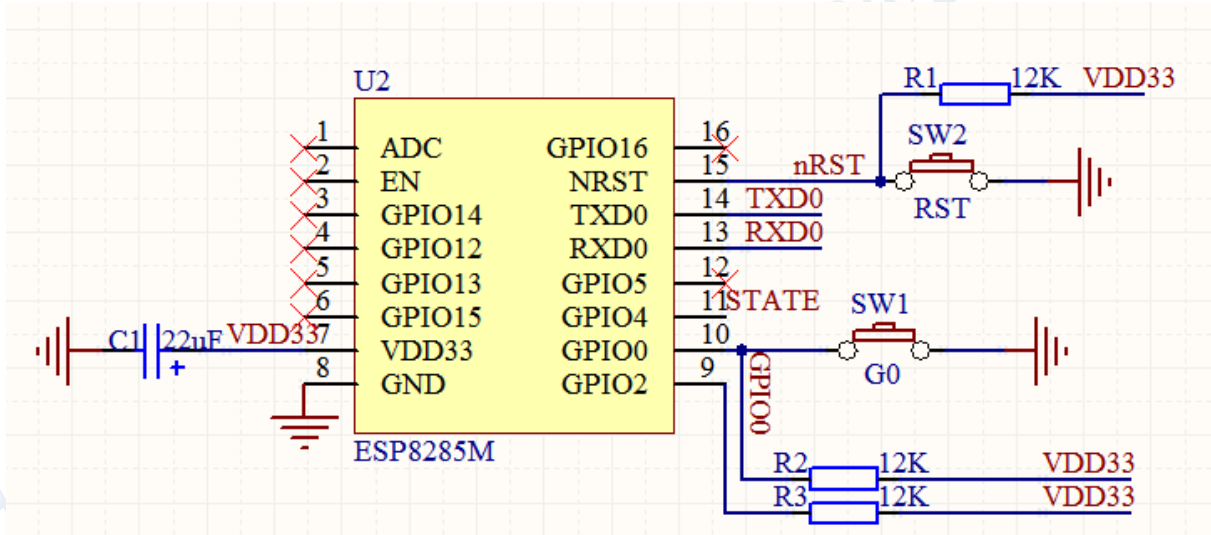

Fig. 8. 1 Minimum System

Note

- (1) the working voltage for module is DC 3.3V;
- (2) the max current from IO of this module is 12mA;
- (3) RST Pin is enabled when it is low level; and EN pin is enabled when it is high level;
- (4) WiFi module is at update mode: GPIO0 is low level, then module reset to power; Wi-Fi module is at working mode: GPIO0 is at high level, and then reset to power;
- (5) Wi-Fi module is connected to RXD of the other MCU, and TXD is connected to RXD of the other MCU.

9. The Recommended PCB Design (An Example)

Wi-Fi module can be inserted into the PCB board directly. For the high RF performance for the end device, please note the placement for the antenna and the module.

Especially, since the antenna is external for ESP-M1, the antenna can be placed by the project requirements. The connector for external antenna is shown in the following.

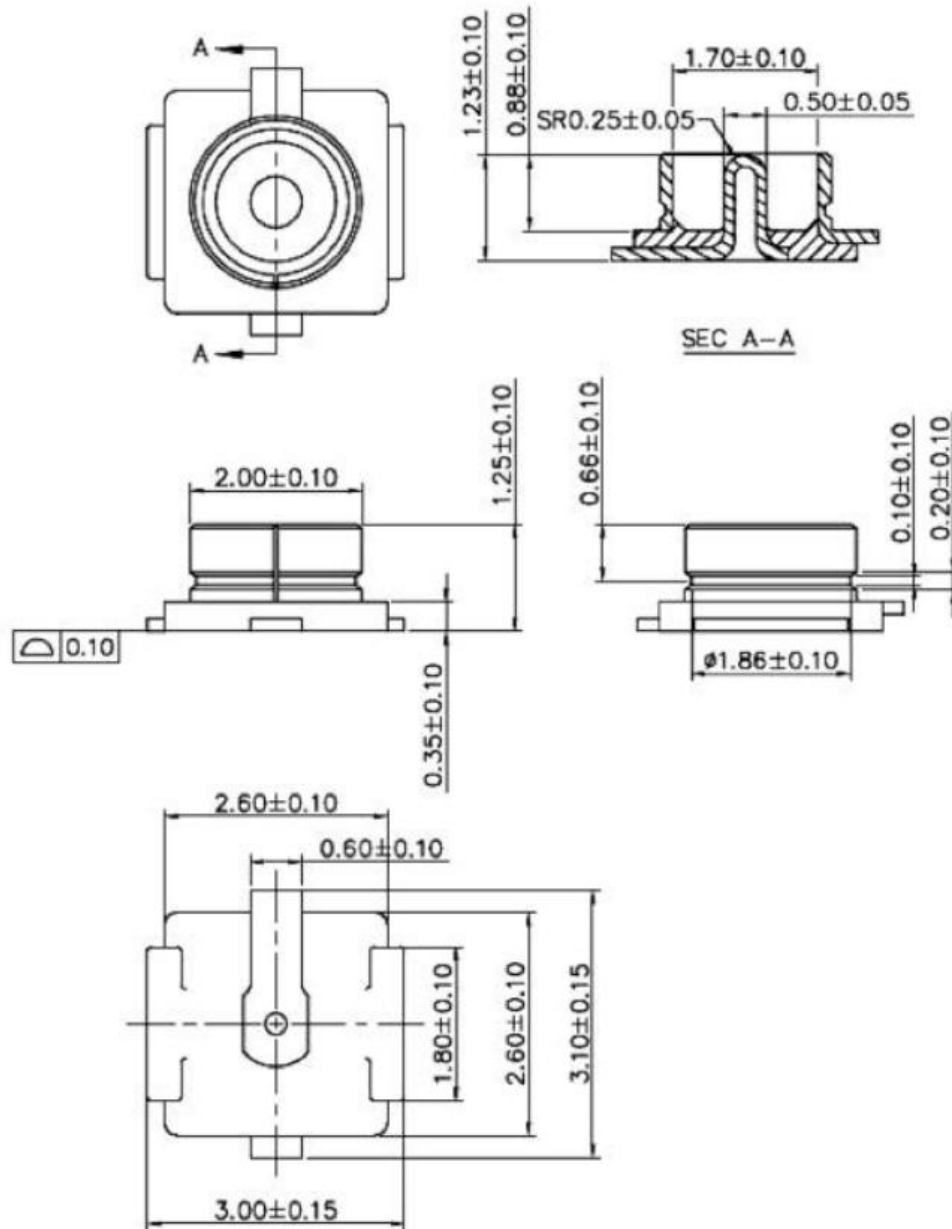

Fig. 9. 1 Connector for the external antenna

It is suggested that the module is placed along with PCB side, the antenna is placed outside the board, or along with the PCB side, and the below board is blank, please refer to the scheme 1 and scheme 2; if

the PCB antenna must placed on the board, please do not cover the copper at the bottom of PCB antenna, as can be shown at scheme 3.

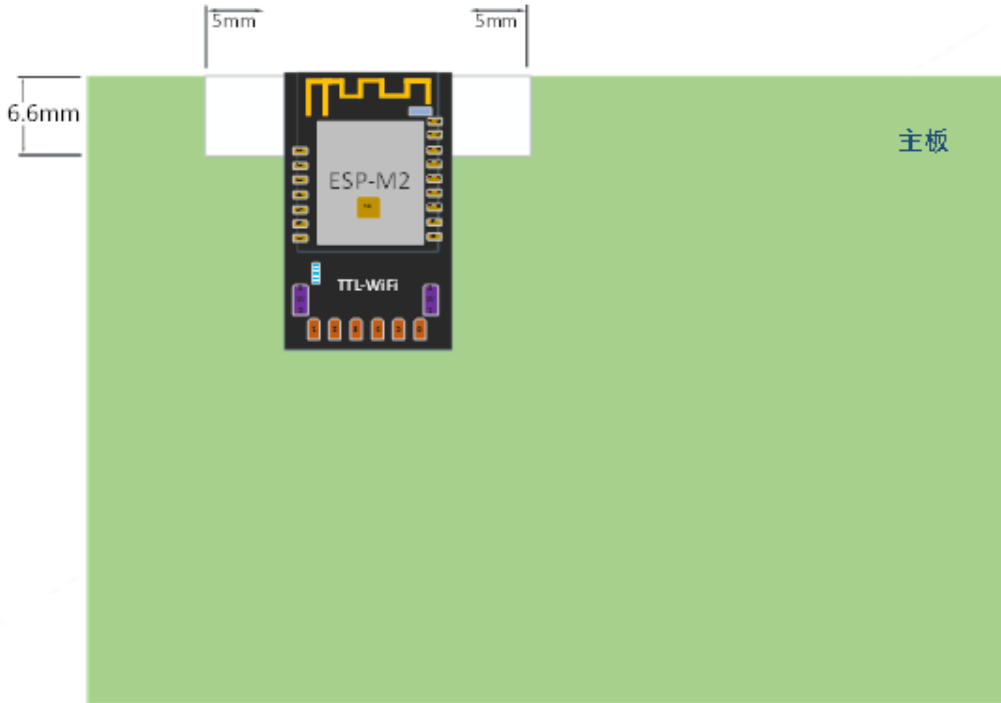

Fig. 9.2 scheme1: Antenna is at the outside of the board

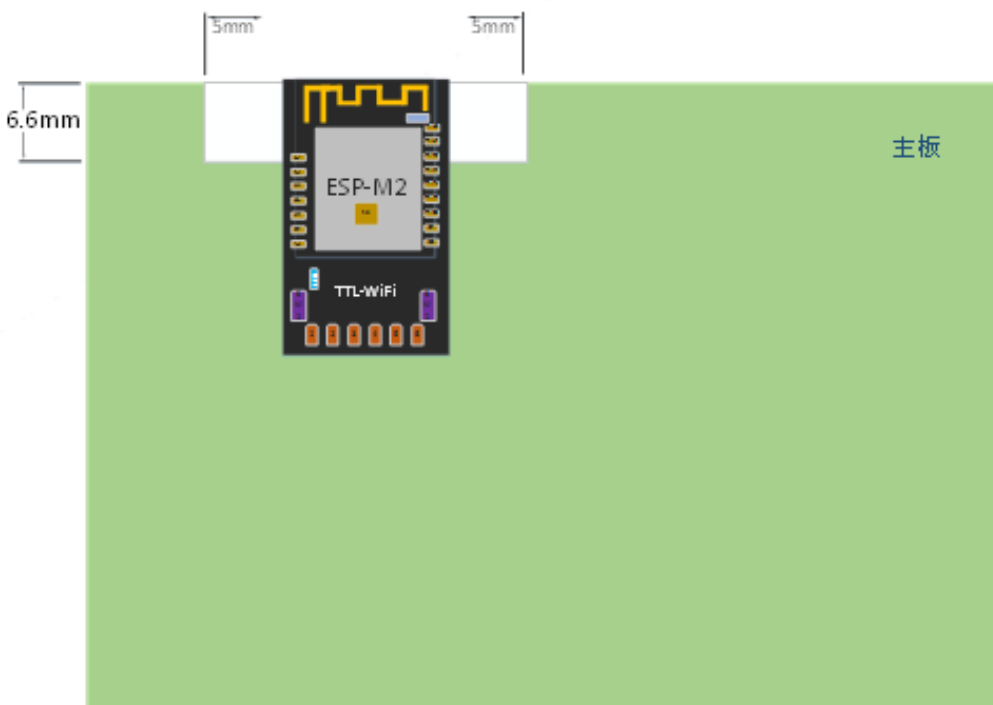

Fig. 9.3 Scheme 2: Antenna is placed along with side of the board, and it is blank at the bottom of the board.

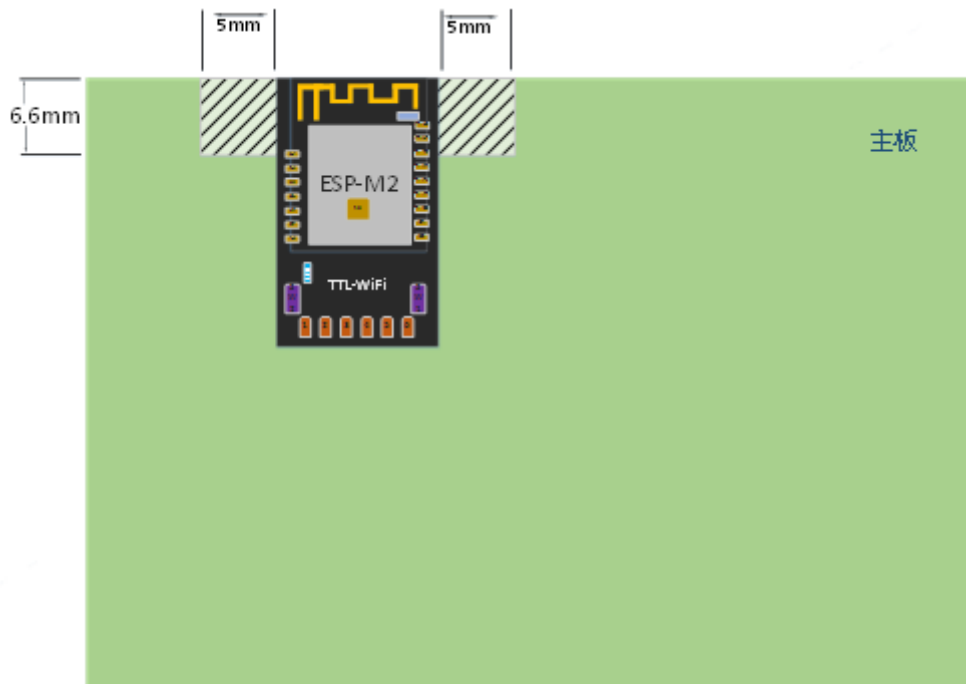

Fig. 9.4 Scheme 3: Antenna is placed along with the side of the board, and don't cover copper under the module

10. Peripheral Line Suggestion

Wi-Fi module is already integrated into high-speed GPIO and Peripheral interface, which may be generated the switch noise. If there is a high request for the power consumption and EMI characteristics, it is suggested to connect a serial 10~100 ohm resistance, which can suppress overshoot when switching power supply, and can smooth signal. At the same time, it also can, to a certain extent, prevent electrostatic discharge (ESD).

Disclaimer and Copyright Notice

The information in this article, including the URL for reference, if there is any change, without prior notice.

Documents are provided by the current version without any guarantee responsibility, including merchantability, suitable for any particular purpose or non-infringement guarantees, and any guarantees presented by any proposal, specification, or sample mentioned elsewhere. This document has no any responsibility, including the use of the information within this document produced by the infringement of any patent rights. This document in this, by estoppel or otherwise, grant any intellectual property licensing, whether express or implied license.

The Wi-Fi alliance marks shall be owned by the Wi-Fi alliance.

All the mentioned brand names, trademarks and registered trademarks presented in this document are the property of their respective owners, and hereby declare.

Notice

Because of the product update or other reasons, this manual may change. Doctors of Intelligence & Technology Co., LTD Keeps the right to change the contents of this manual in the absence of any notice or reminders. This manual is used only as a guide, Doctors of Intelligence & Technology Co., LTD would try their best to provide the accurate information in this manual, but it does not ensure that the manual content is completely right and national, all the statements in this manual, and information and advice do not mean to provide any express or implied guarantees.

